

stelton



My Choices

Our Spring collection is shaped by the choices we make in everyday life. In a time defined by movement and repetition, it reflects a more inward focus—where quality, use and personal rhythm matter more than trends.

From objects designed to follow daily routines to pieces chosen to stay over time, each design is created with intention. Materials and colours are selected to support how life is lived, allowing the objects to become part of everyday moments rather than stand apart from them.

At Stelton, design has always been about use. About creating objects that earn their place through clarity, durability and quality. Rooted in our design heritage and shaped by a contemporary way of living, we continue to develop collections that balance tradition with a modern, personal perspective.

With a focus on steel, refined finishes and new colours, this collection brings a calm confidence to everyday life. Welcome to My Choices—where considered design supports the way you choose to live.

Simple, clean, and always in style.



White brings a quiet sense of calm to the home and makes room for everything else to shine. Whether it's the backdrop to a busy kitchen or a soft accent on a table setting, white fits in effortlessly. It's the color that never asks for attention, yet always adds a feeling of freshness and balance.

Made in Denmark since 1977

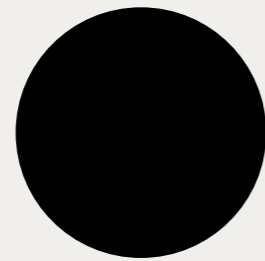

ABOVE: EM77 vacuum jug by Erik Magnussen and Theo sugar bowl and milk jug by Francis Cayouette.

Designed to last a lifetime



The EM77 vacuum jug was designed to last a lifetime, as all the components can be replaced if they should break. This extends the service life of the vacuum jug, thereby benefiting the environment.

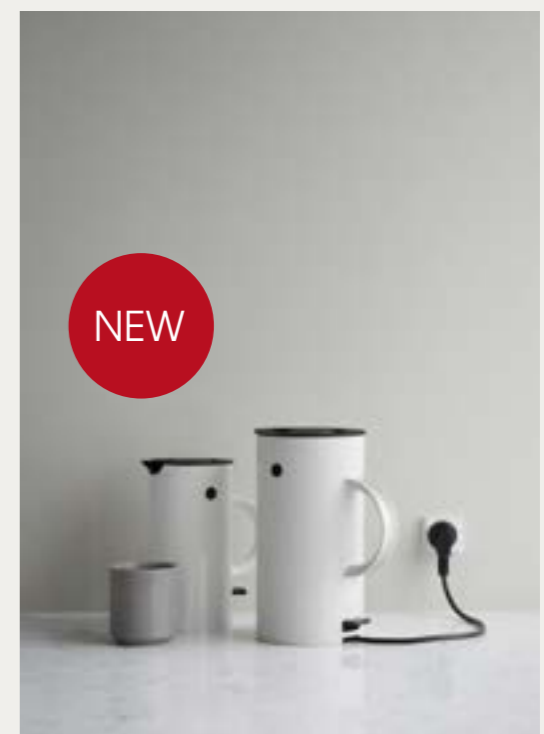

The EM77 series, designed by Erik Magnussen, reflects a deep understanding of form and function. This versatile collection features Danish design icons—where form pleases the eye and function refines the taste.

The SS2026 colors bring a sense of balance that naturally slows us down.



TOP: Arne Jacobsen's Green Laboratory—The Garden at Sølholm. Green, compact garden rooms with ferns and bamboo throughout.
BOTTOM: To Go Click in soft fern green.



Inspired by the calm of early spring—dew on leaves, the sky after rain—the SS2026 colors bring a quiet sense of balance. Soft greens and gentle blues create an atmosphere that naturally slows us down.

The green grounds us, offering clarity and a gentle feeling of renewal. The blue opens up a room, softening our surroundings and easing the mind.

Whether through textiles, table settings, or small accents, these natural tones reduce visual noise and add a calming flow to any space.



TOP LEFT: EM77 vacuum jug soft cloud, EM77 jug with lid blue, EM serving tray cloud, and Stelton's new Soft Home Vibeke Klint bedding in blue. MIDDLE LEFT: Keep Cool and EM77 vacuum jug soft fern green, Original flower watering can soft dark forest, and Stelton's new Vibeke Klint bedding in green. BOTTOM RIGHT: EM77 vacuum jug sand, Original flower watering can soft sand, and Stelton's new Vibeke Klint bedding in white.

Classic color contrast

Create contrast to a calming base by adding a splash of warmth. Red doesn't take over the space—it simply draws the eye. Warm and expressive, it adds energy and focus where needed, bringing life and rhythm to calm surroundings. Used in small details, red adds depth and character without disturbing the balance.

Timeless and instantly recognizable, red has been a Stelton classic for decades. Seen in both iconic designs and subtle accents, it represents confidence, clarity, and lasting design—just as relevant today as ever.

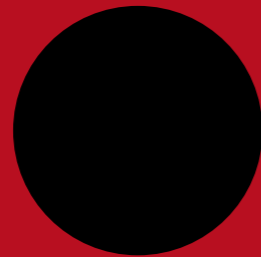

First launched in 1979, the red EM77 vacuum jug remains a Stelton classic.

Erik Magnussen in his studio, working on one of his chairs, with the red EM77 vacuum jug placed casually on the table, standing out as a bold, graphic icon.

What makes a shape iconic? This year we explore not just the objects that define Stelton—but the people behind them. My Shape invites you into the personal design journeys of creatives who have left a unique mark on our brand. From modern reinterpretations of classic Stelton values to the foundational icons that

shaped our DNA, we delve into the form—and the thinking—that define each designer's shape. A form that balances function and aesthetics. A form rooted in minimalism and guided by material honesty often expressed through the enduring strength of steel. A form that continues to shape Stelton's past, present and future.

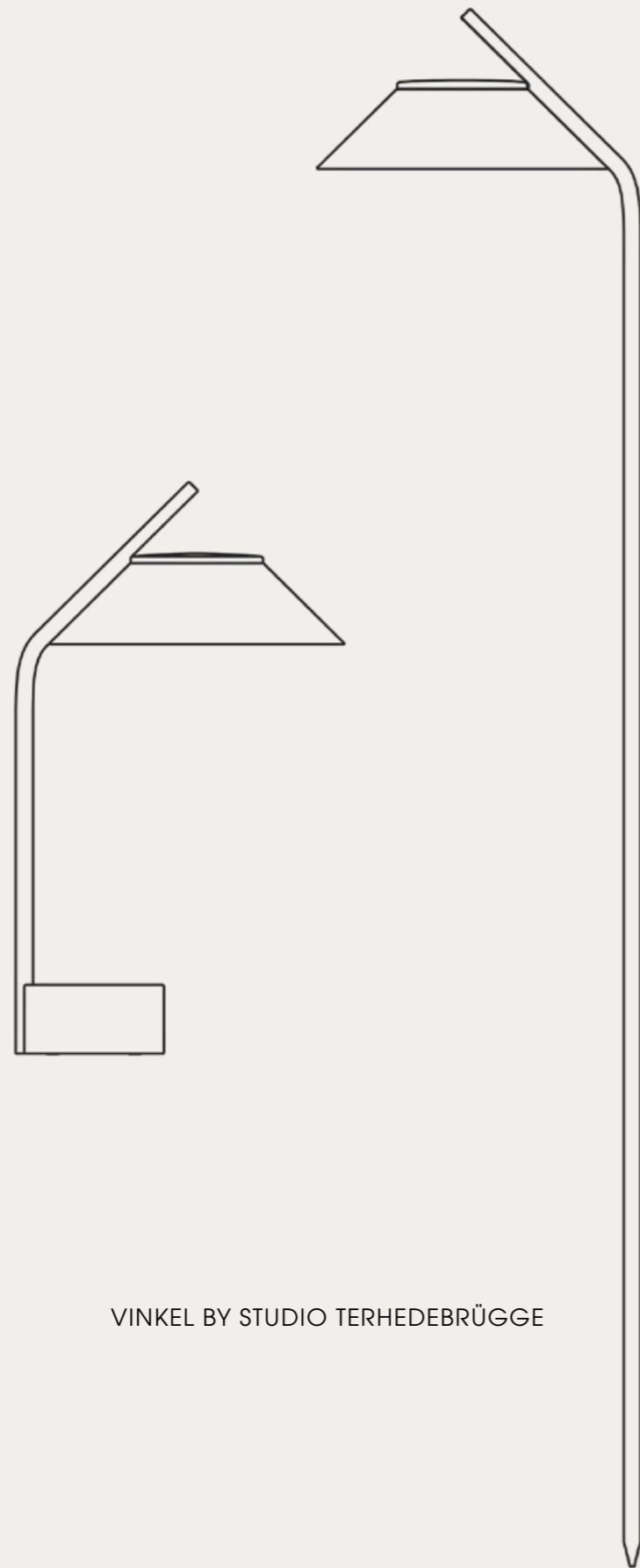

VINKEL BY STUDIO TERHEDEBRÜGGE

Clean and understated, Vinkel is a versatile lamp series by Studio Terhedebrügge. With simple lines, intuitive features, and a soft, atmospheric light, Vinkel is made to fit naturally into any setting.

VINKEL BY STUDIO TERHEDEBRÜGGE



“You can see at a glance when proportions work: the mass feels grounded, the transitions are calm, the outline can be read in one breath.”

— Studio Terhedebrügge

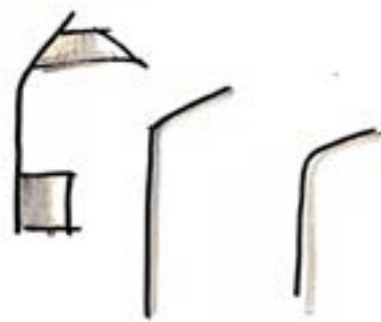

The new Vinkel LED lamp series, designed by Studio Terhedebrügge, is created to set the mood both indoors and outdoors. The portable table lamp features an integrated battery, three touch-controlled brightness levels, and convenient USB-C charging. The outdoor spike lamp complements the series with a built-in solar panel and light sensor that automatically switches the light on at dusk and off at dawn, with the option for manual control. Together, the Vinkel lamps unite functional design with a soft, welcoming glow—perfect for creating cozy moments.



ABOVE: Vinkel LED lamp



MY INSPIRATION

Q&A WITH STUDIO TERHEDEBRÜGGE

Based in Berlin, Studio Terhedebrügge is an award-winning interdisciplinary design studio led by siblings Silvia, Antonia and Julius Terhedebrügge. Working at the intersection of object design and visual communication, the studio moves fluidly between art, culture and design. What began as a shared curiosity in their youth has developed into a mature practice shaped by experimentation and clarity of form. The trio brings together complementary disciplines: Antonia is trained in graphic design, while Silvia and Julius studied product design at the Berlin University of the Arts. Their joint efforts have been recognised through distinctions including an award from the German Design Council. We spoke with the trio about inspiration and design.

What inspires you?

For us, inspiration primarily means maintaining our level of attention. One of us once had a bit of an obsession with grain silos and their different forms. The concept was straightforward: to take minimalist photos of silos against a clean blue sky, ensuring that no other elements were in the frame. Without the background, the essentials are easy to recognise: lines, balance and proportion. The details are no longer hidden. Soon it wasn't just silos anymore; cranes, parts of roofs, gutters, antennas, handrails and chimneys joined the album. This collection of "objects on blue" is inspiring because it removes context and shows what actually carries a form—what to keep, what to cut, and how the proportions should read. You can see at a glance when proportions work: the mass feels grounded, the transitions are calm, the outline can be read in one breath. And you can see when they don't: top-heavy, pinched in the middle, or fussy where it should be quiet.

Similarly, inspiration can simply be derived from the process of creation. A blank sheet of paper, which might be a nightmare for a writer, is for us the quickest start to a new idea. We have the capability to pick it up, cut, bend and fold it; the hands get to play while the head stays light. Prototyping is a process that allows us to turn abstract ideas into tangible solutions. This approach enables us to engage with the concept in a physical and tangible way, allowing our minds to process and grasp the idea more effectively.

What surprised you most about working with Stelton?

The biggest surprise was how the small team enabled such a quick and honest exchange of thoughts. From the initial discussions, Stelton grasped the vision for the lamp—its character, priorities and subtle details—and it felt as though they perceived the lamp in the same way as us. We were on the same wavelength regarding aesthetics and functionality, an alignment that enabled us to make quick decisions and maintain a clear design.

What do you hope people experience when they hold one of your designs?

We spend a considerable amount of time on details that go unnoticed, but that's the point. If the hand says 'yes' before the head does, then the radius and proportions have done their job. The object should feel easy to hold and easy to place, and it should look like it has always belonged there.

On a more serious note, we all have objects that bring us joy every day, not just in the week after purchase. Over time, they earn a place in our routines and we build a relationship with them. If one of our designs becomes that kind of companion—not just 'a lamp', but 'my lamp'—then we're genuinely happy.

"To us, Stelton's ethos embodied clarity and restrained elegance, characterised by clear geometry, authentic materials, and a design philosophy that prioritises longevity over noise. The collection reads like everyday tools refined to the point of calm—objects that don't demand attention but instead earn it over time."

— Studio Terhedebrügge

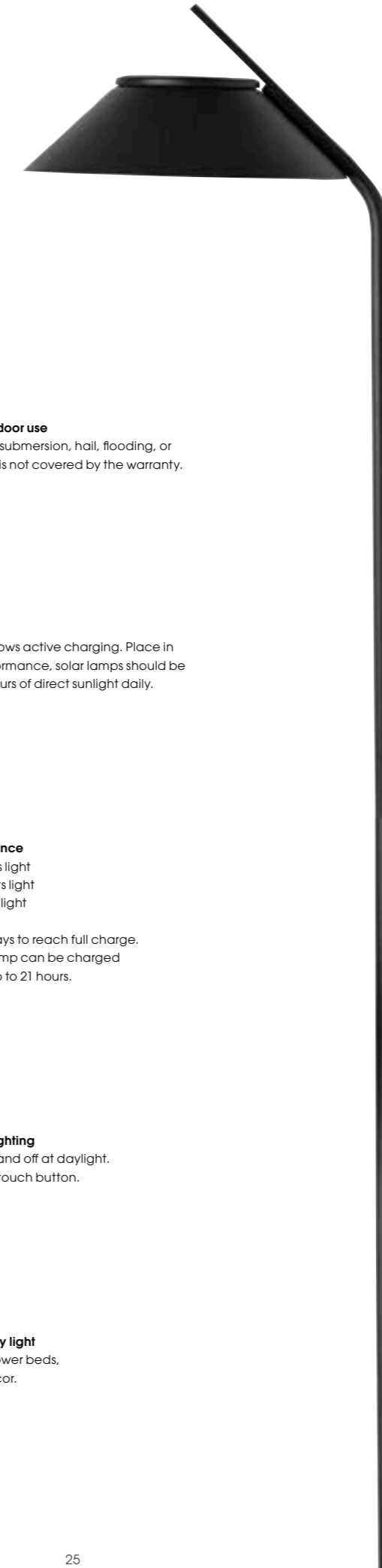

Waterproof IP65-rated for outdoor use

Protected against dust and rain. Not designed for submersion, hail, flooding, or high-pressure water. Damage from such conditions is not covered by the warranty.

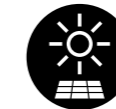

100% solar-powered

Charges exclusively with sunlight. Red indicator shows active charging. Place in a sunny spot for best performance. For optimal performance, solar lamps should be placed where the solar panel gets at least 3 hours of direct sunlight daily.



Weather-based performance

Sunny: 8 hrs charge → 8 hrs light
 Cloudy: 8 hrs charge → 3 hrs light
 Rainy: 8 hrs charge → 1 hr light

For longer use, keep the lamp off for a few days to reach full charge. In perfect sunlight conditions, the solar lamp can be charged in 18 hours, with a working time up to 21 hours.



Automatic dusk-to-dawn lighting

Auto mode turns the lamp on at sunset and off at daylight. Activate with a 3-second press on touch button.



2700 Kelvin – warm and cozy light

Ideal for pathways, gardens, flower beds, patios, and outdoor décor.

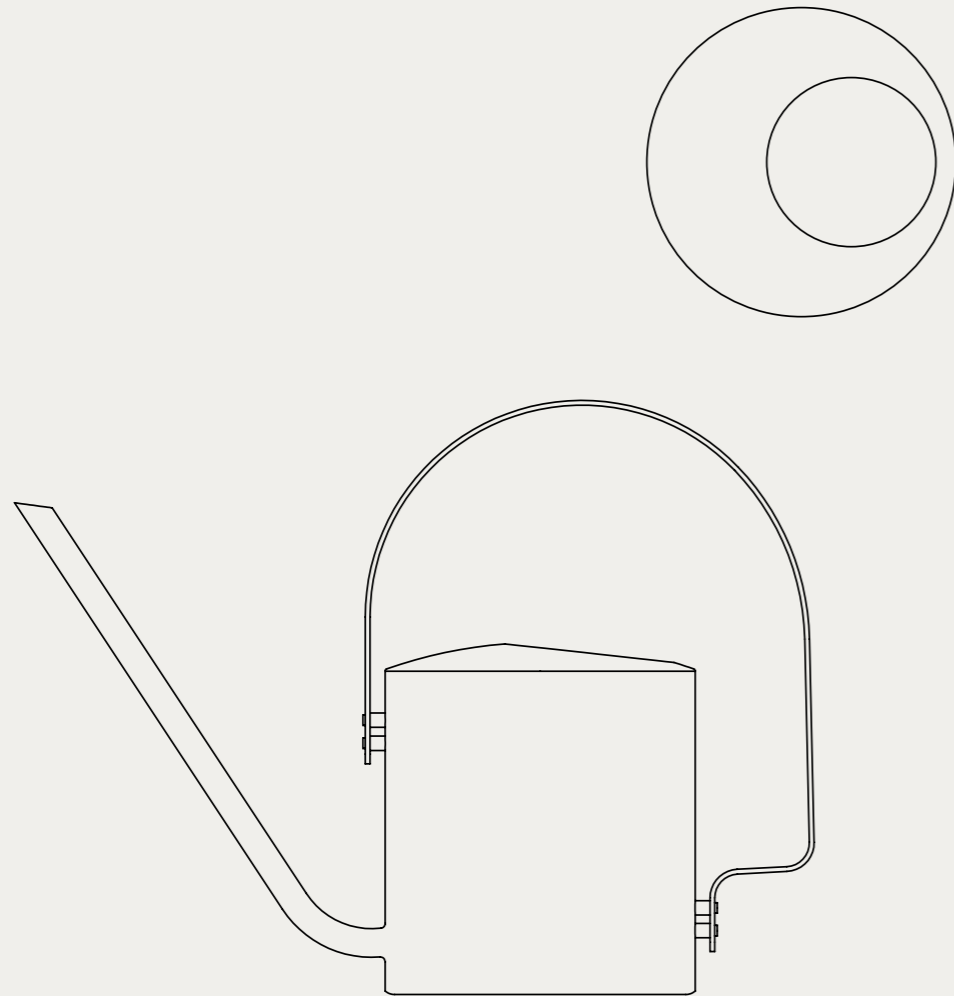

ORIGINAL BY PETER HOLMBLAD

The Original series, by Peter Holmblad, stands as a tribute to Stelton's design DNA. Holmblad's vision, shaped through his close collaboration with Arne Jacobsen, marked the beginning of a new era for Stelton.



NEW

My Original choice

ABOVE: Original flower watering can in steel



Peter Holmblad played an important role in shaping Stelton as a design brand. Holmblad designed several iconic products, including the Original series. His vision and collaboration with Arne Jacobsen led to the legendary Cylinda-line—marking a new era for Stelton.



The Original flower watering can is part of the Original series, a cornerstone of Stelton's design DNA. With its elegant shape, functionality meets aesthetics, and in addition to its original purpose—keeping flowers and green plants fresh—it also serves as a decorative sculpture when not in use.

Alongside the classic stainless steel version, the Original flower watering can is launched this season in soft black, soft dark forest, and soft sand.

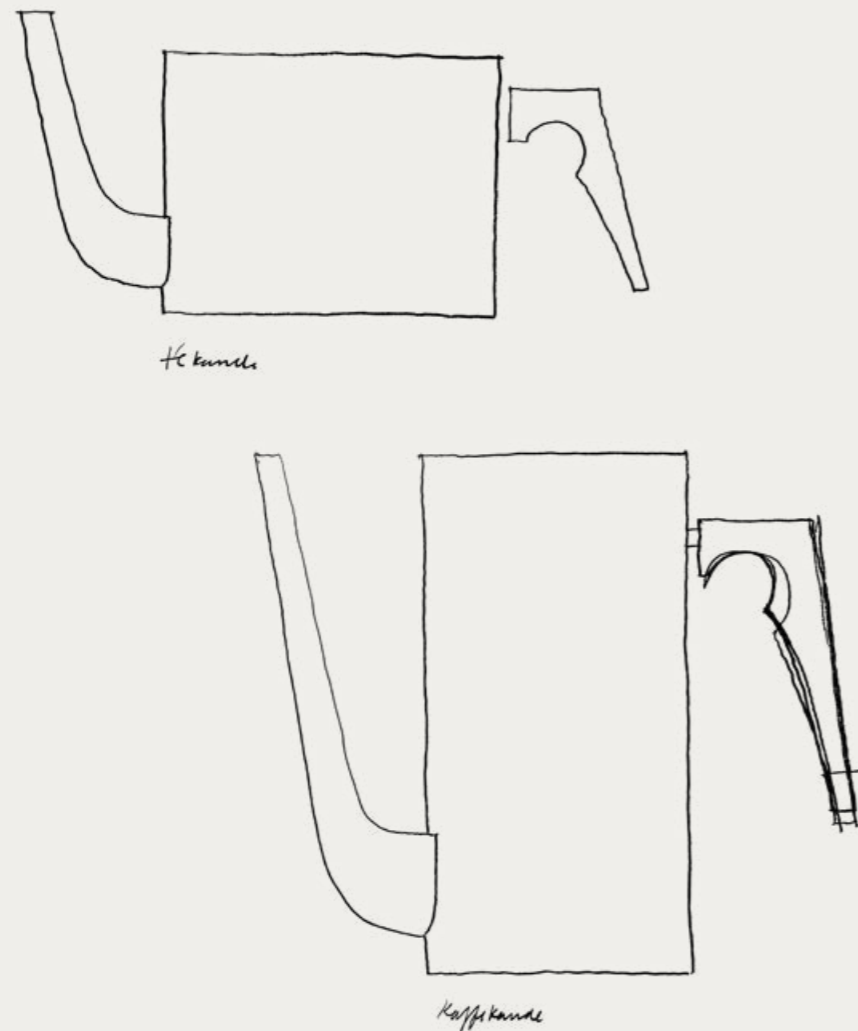

CYLINDA-LINE BY ARNE JACOBSEN

Arne Jacobsen's vision for Cylinda-line was that the series should enrich the ordinary consumer with good industrial design. With his design, he realized some of the most important ideas from functionalism—total proportionality between form and function.

Arne Jacobsen designed the award-winning Cylinda-line series for Stelton in 1967 and it remains the heart of Stelton's design DNA.



Arne Jacobsen is one of the most recognised Danish architects worldwide. Uncompromising in his approach, Jacobsen went beyond architecture to design furniture, lighting and interiors.

Arne Jacobsen played an important role in modernism and Danish design history, and present-day designers are still highly influenced by his works. He had an extraordinary understanding of proportion, which he applied to his designs.



LEFT: Arne Jacobsen coaster, French press, teapot, creamer, and sugar bowl.
RIGHT: Arne Jacobsen serving tray, coaster, cocktail shaker, ice bucket, ice tongs, serving jug, and martini mixer with spoon.

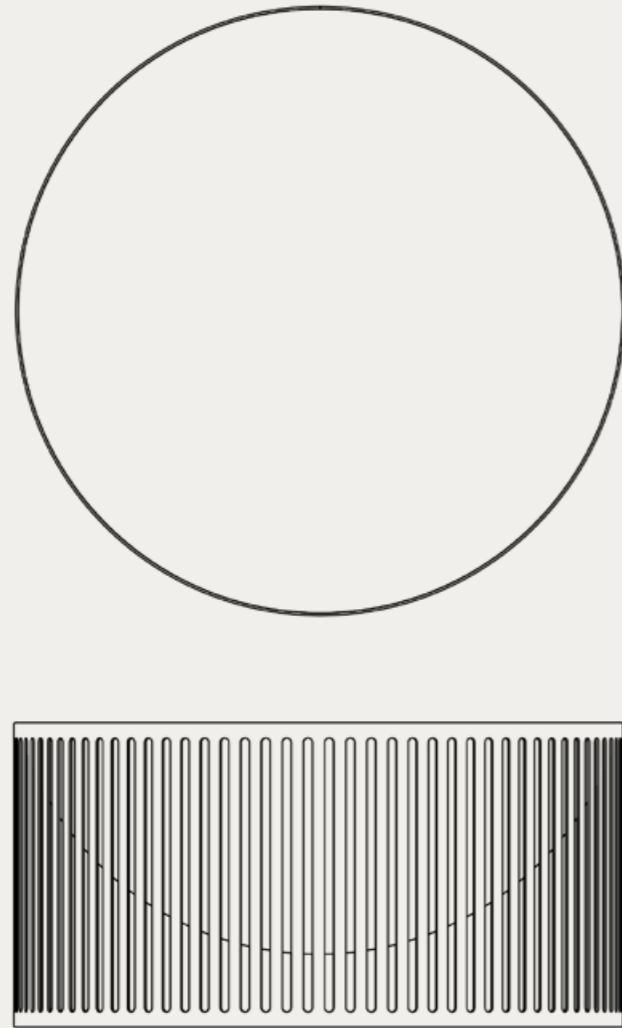

ORLO BY DEFNE KOZ

Sculptural yet restrained, Orlo reinterprets classic Stelton values through a contemporary, minimalist lens. Orlo balances durability with timeless elegance, drawing a clear line back to the iconic Cylinda-line and Stelton's enduring DNA in stainless steel.

Classic Stelton, reimagined

NEW



ABOVE: Orlo serving bowls, serving tray.

With the Orlo collection, Stelton introduces a new collaboration with Defne Koz of Koz Susani Design in Chicago—drawing a clear line back to the iconic Cylinda-line and Stelton’s enduring design DNA in stainless steel. Sculptural yet restrained, Orlo reimagines classic Stelton values through a contemporary, minimalist expression.

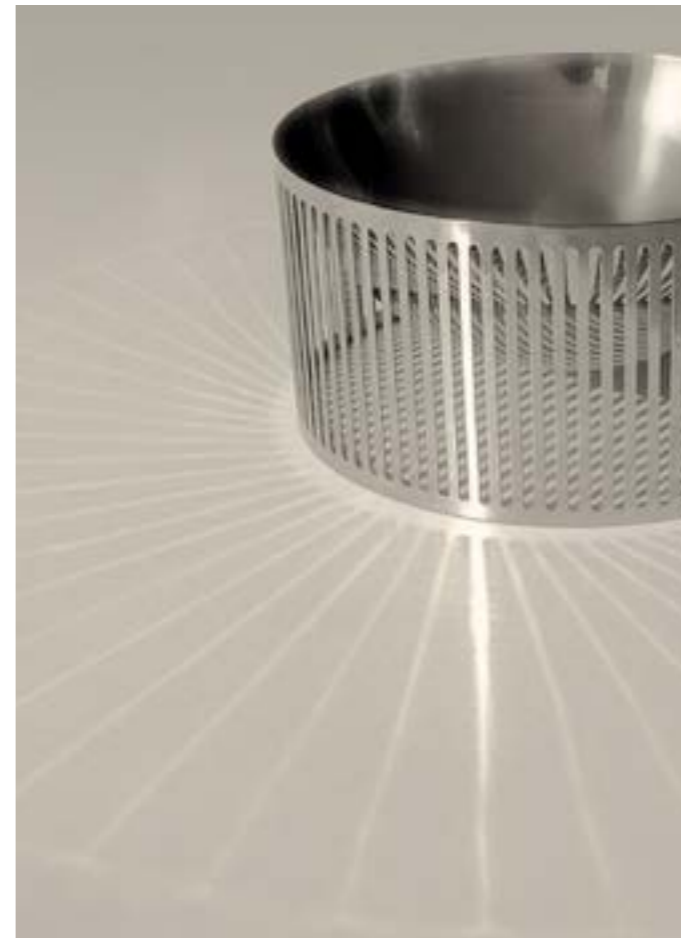

Defne Koz

Rooted in the cultures of Turkey and Italy, Defne Koz designs objects that quietly resonate—where innovation meets emotion and timeless form. As co-founder of Koz Susani Design in Chicago, her work reflects a deep sensitivity to material, presence, and quality. Her aesthetic aligns naturally with Stelton’s heritage of thoughtful, enduring design.

Crafted in stainless steel, Orlo balances durability with timeless elegance. The soft, circular form gives the pieces a sculptural presence, while their simplicity allows them to integrate effortlessly into a wide range of interiors and table settings.

Available as a 10 cm and 8 cm serving bowl and a 4 cm serving tray, Orlo combines sculptural simplicity with everyday functionality—ideal for serving, storage, or display.

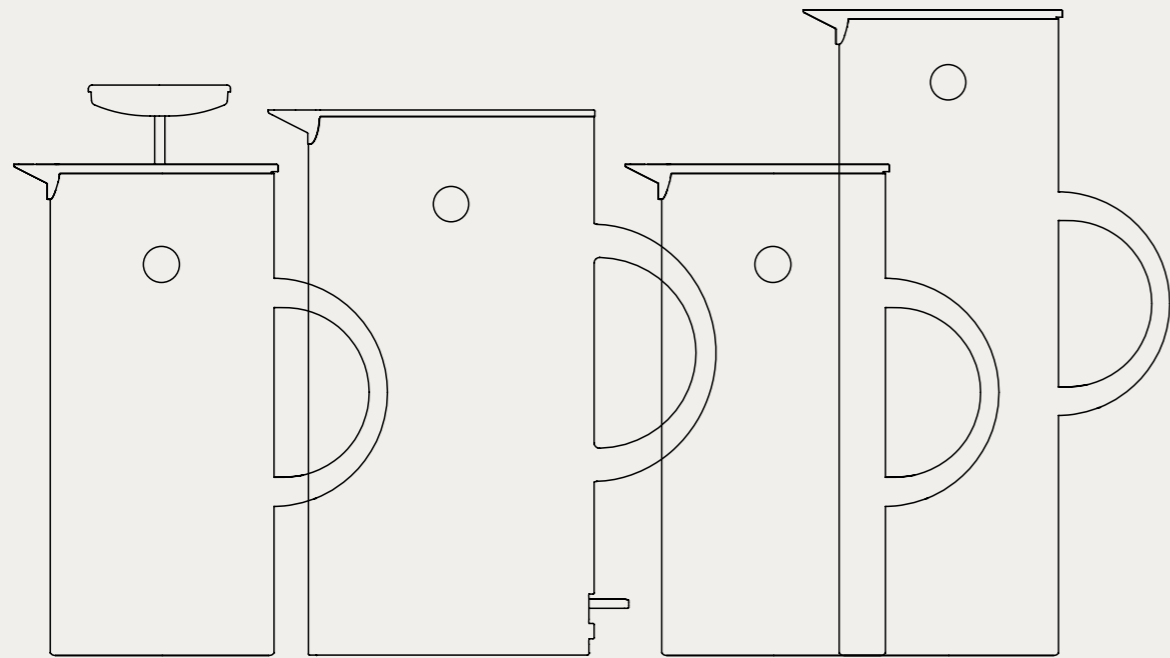

EM77 BY ERIK MAGNUSSEN

The EM77 series, designed by Erik Magnussen, reflects a deep understanding of form and function. This versatile collection features Danish design icons—where form pleases the eye and function refines the taste.

The story behind a design icon.



When Stelton set out to create a vacuum jug to complement Cylinda-line—Erik Magnussen was entrusted with the task. The result was the EM77: a vacuum jug that echoes the Cylinda-line's signature cylindrical form and minimalist expression, uniting functionality with timeless design.



ABOVE: EM77 jug with lid, water filter jug, French press, tea strainer, dripper, vacuum jug 0.5 l and 1 l, electric kettle 1 l and 0.5 l.

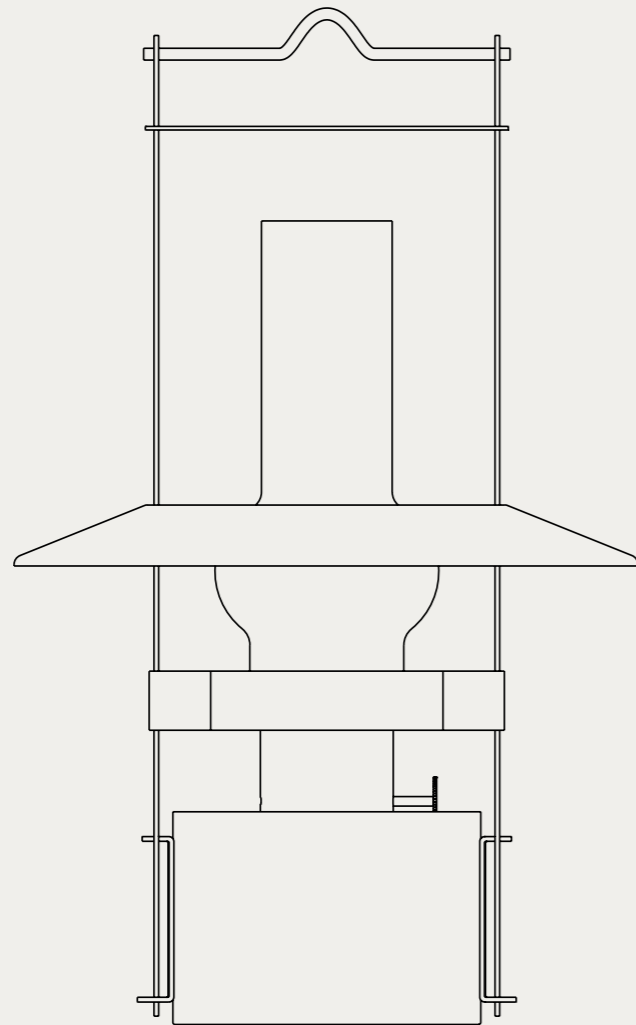

EM SHIP'S LAMP BY ERIK MAGNUSSEN

Erik Magnussen's ship's lamp is a cornerstone of Stelton's stainless steel collection—a true design classic where function and form come together seamlessly. Its clean, cylindrical shape places it firmly within Stelton's long tradition of timeless stainless steel designs.

Designed to last



ABOVE: EM LED ship's lamp.



Introduced in 1982, Erik Magnussen's ship's lamp reflects a design approach that remains highly relevant today. Its clean, cylindrical form and warm, atmospheric light fit naturally into contemporary interiors, where simplicity and function are key. From the beginning, the lamp was praised for its beautiful light. True to Magnussen's functional approach, it also provided heat and helped reduce humidity —making it ideally suited for life at sea as well as summer cottages.

Today, the design is as relevant as ever and continues in a new LED edition, crafted in satin-polished stainless steel and preserving the clean, cylindrical form that defines the original. The classic EM ship's lamp remains available with a traditional burner.



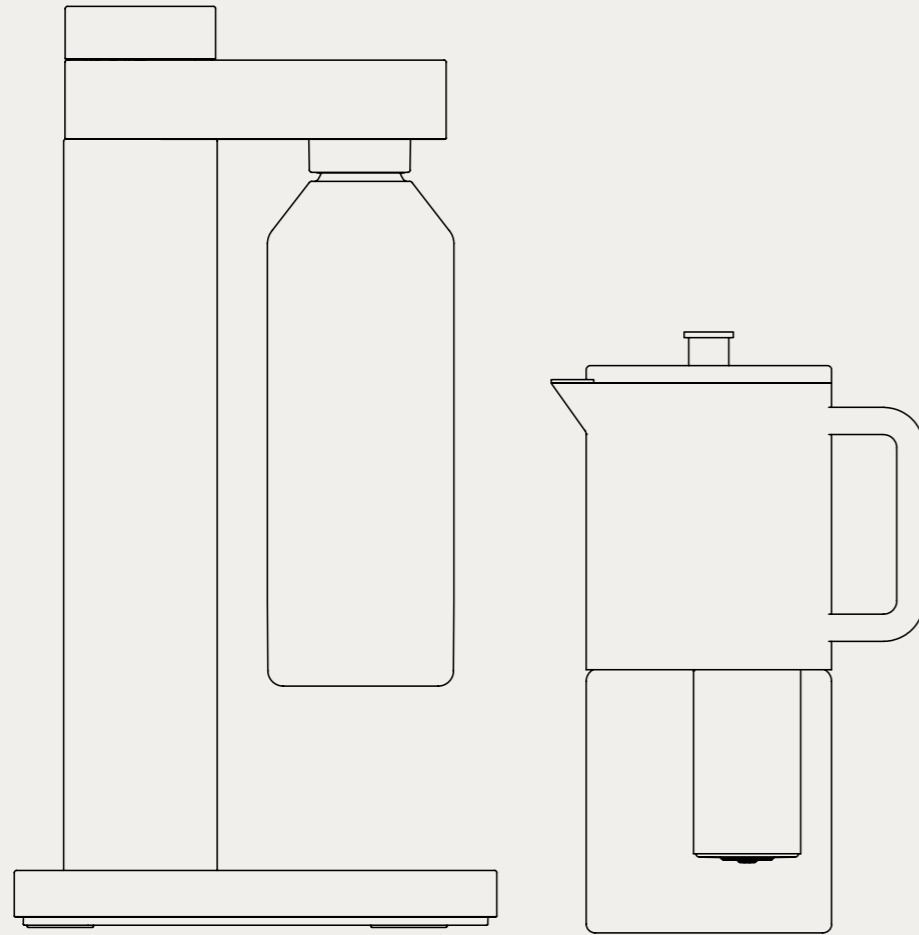

BRUS BY SØREN REFSGAARD

The minimalist design of Brus reflects the Scandinavian design tradition and is a typical example of designer Søren Refsgaard's desire to cut away all that is superfluous. The design draws on the cylindrical shapes that are classic to Stelton designs.

Minimalist elegance



ABOVE: Arne Jacobsen coaster and ice tongs, Pilastro long drink glass and bowl, Brus carbonator and carbonating bottle.

The minimalist design exudes a timeless elegance, which has quickly made Brus noticeable. From the sleek container to the carbon dioxide cartridge and the intuitive carbonation button, every single detail is created with a focus on simplicity and user-friendliness.



Søren Refsgaard plays an important role in shaping Stelton as a design brand. Refsgaard is a Copenhagen-based designer rooted in the Danish design tradition, his work is defined by clean lines and functional clarity, striving for a balance between simplicity and character by removing the unnecessary without losing the soul of the design.



Brus is also available in a wall-mounted version and comes in steel, black metallic, dark brown metallic, brushed brass, soft sand, soft black, and soft white.

Clarity, simplicity and care

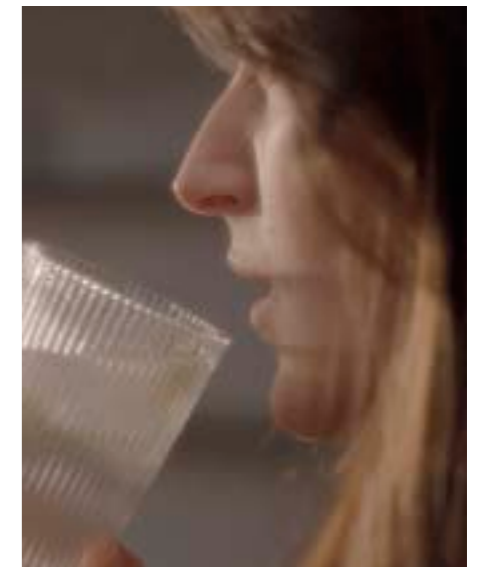

NEW

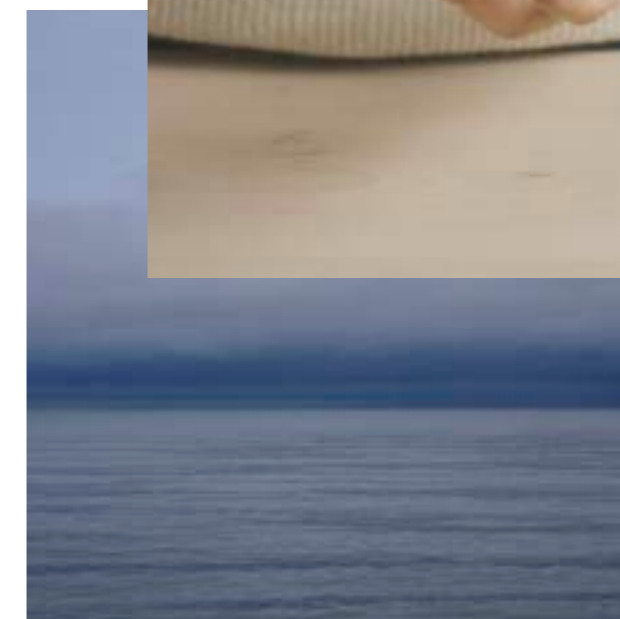

ABOVE: Brus carbonator and water filter jug designed by Søren Refsgaard.

My water is clarity, simplicity and care. Designed with purpose and made to bring pure water into everyday rituals. Experience the benefits of clean, soft and better-tasting water with the Brus water filter jug, and Brus Clear+ and Magnesium+ water filter.

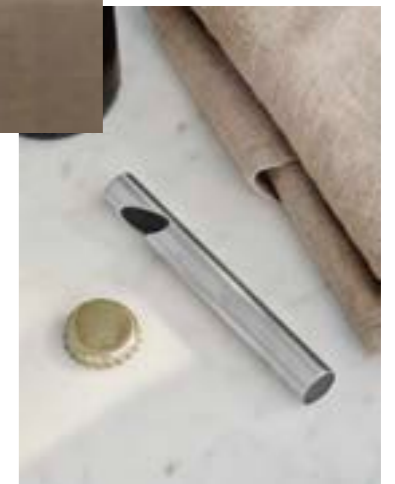

**The beauty
is in the details**



AMPHORA BY SEBASTIAN HOLMBÄCK

Shaped by history and designed for today, Amphora is inspired by ancient Greek amphorae once used to store and transport precious liquids. Designer Sebastian Holmbäck reinterprets the vessel's rounded body and distinctive shoulders in a contemporary form that bridges past and future.

Timeless elegance



ABOVE: Amphora vacuum jugs and electric kettle.

Award-winning designer Sebastian Holmbäck brings his creative expertise to The Amphora Collection for Stelton, combining timeless elegance with modern functionality. His vision and attention to detail have made The Amphora Collection a popular choice, reflecting his unique approach to contemporary design.



The Amphora vacuum jug in stainless steel is dishwasher safe and will keep your coffee or tea hot for hours.



EMMA BY HOLMBÄCKNORDENTOFT

With its simple, elegant lines, the Emma series brings warmth and beauty to everyday moments. Designed by HolmbäckNordentoft, the collection is inspired by Scandinavian design traditions and combines soft forms with natural materials in a timeless, inviting expression.



ABOVE: Emma electric kettle and French press



Sebastian Holmbäck and Ulrik Nordentoft met at the Danish Design School, where they both trained. Almost 10 years after their graduation, they established the HolmbäckNordentoft studio. Their common ground, and the basis for all their work, is aesthetics. The studio works in a wide range of design areas, including interior design, furniture, lighting, industrial design and product design, which is their primary focus.



The Emma series, with its simple and elegant lines, is a beautiful addition to any kitchen counter or table. This combination of stainless steel with details of moulded beech wood fits perfectly into a modern home. In the Emma collection, you will find everything you need to set an inviting table from cups and plates to vacuum jugs, electric kettles and French press.

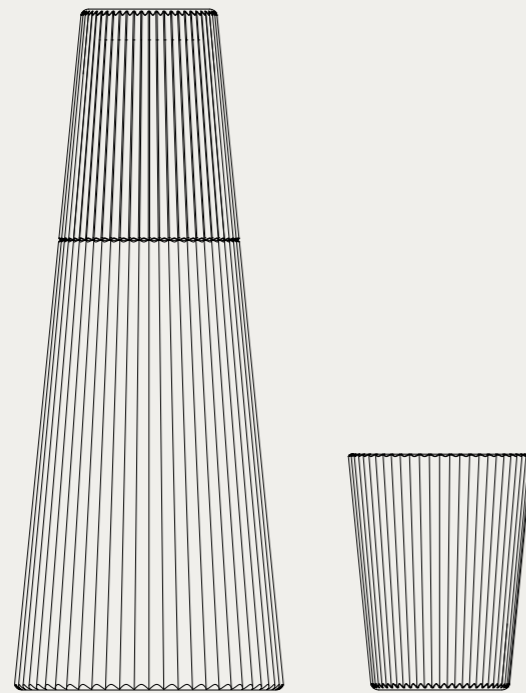

PILASTRO BY FRANCIS CAYOUE

The Pilastro series, designed by Francis Cayouette, reflects a deep understanding of everyday life. Inspired by the Art Deco movement, the collection features fluted details that combine classic design with modern versatility.



Francis Cayouette is a Canadian designer based in Copenhagen since 1999, where he runs his studio Unit10. Educated in Montreal and Paris, he collaborates with both Scandinavian and international brands to create thoughtful, functional products.

The Pilastro series, designed by Francis Cayouette, reflects a deep understanding of everyday life. Inspired by the Art Deco movement, the collection features fluted details that combine classic design with modern versatility.

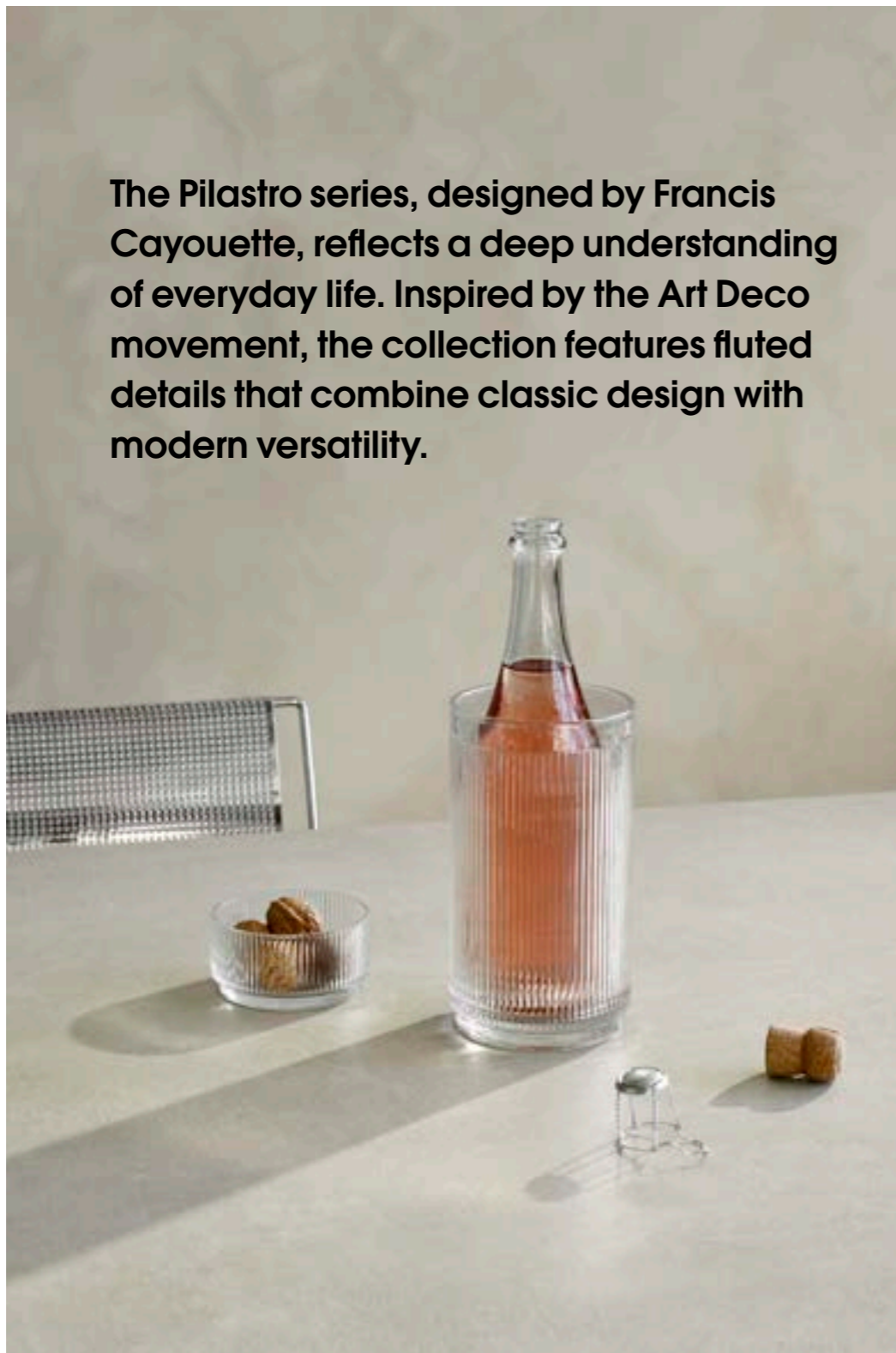

New Pilastro ovenproof dishes in ribbed glass with a minimalist and timeless design. Perfect for baking and serving—straight from oven to table. The heat-resistant glass combines function and aesthetics, adding a refined touch to any table setting.

Francis Cayouette's designs masterfully balance form and function—transforming everyday life into something special.



LEFT: Pilastro carafe with glass and drinking glasses
RIGHT: Pilastro storage jar



The new elegant and practical storage jar in ribbed glass adds a refined touch to any kitchen. Ideal for spices, nuts, tea, coffee or other dry goods, and the airtight seal preserves both freshness and aroma.



STELTON SOFT HOME BY VIBEKE KLINT

Passion defined Vibeke Klint's life and work. Devoted to weaving, colour, and craft, she believed textiles could be both functional and artistic. With the Soft Home collection, Stelton pays tribute to her legacy—reinterpreting classic craftsmanship through a contemporary Scandinavian lens.

Soft Home

NEW



TOP: Arne Jacobsen's Green Laboratory — The Garden at Sølholm. Green, compact garden rooms with ferns and bamboo throughout.
 BOTTOM: To Go Click in soft fern green.

Stelton now enters the world of textiles with a heartfelt homage to the legendary Danish weaver Vibeke Klint. Rooted in her remarkable design legacy, the Stelton Soft Home collection bridges classic craftsmanship with contemporary Scandinavian aesthetics, rediscovering timeless techniques through a modern lens infused with an unexpected edge.



Vibeke Klint (1927–2019) was the queen of minimalist textiles, known for her simple, graphic style. Her rugs, textiles, and site-specific decorations had a profound impact on Danish textile art, and she is today regarded as a significant contribution to Danish design history.

Passion defined Vibeke Klint's life and work. The Danish textile artist was deeply devoted to weaving, colour, and the expressive power of craft. She believed textiles could be both functional and artistic—and through her passion, she elevated textile art to a new level.

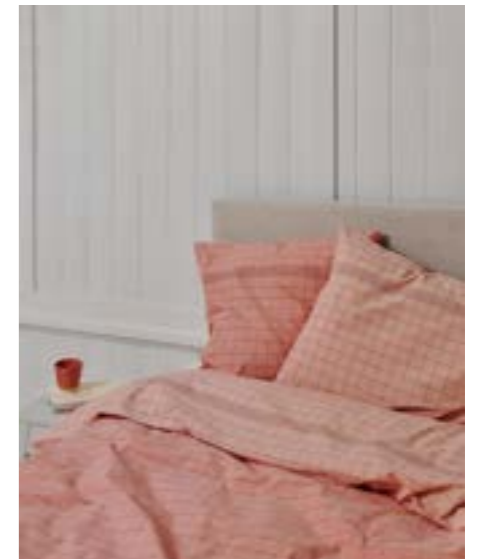

At the core of the collection are Klint's original winding samples—intimate compositions of thread and colour that capture her poetic approach to form and rhythm. With great care, Stelton has reinterpreted selected works, honouring Klint's artistry while creating a new visual narrative defined by bold contrasts and subtle statements.

MADE FROM 90% RECYCLED STAINLESS STEEL

Crafted in high-quality vacuum-insulated steel made from 90% recycled stainless steel. Thoughtful, durable designs for an elegant, environmentally conscious life on the go.

To Go Click 0.2 l



3 hours warm



6 hours cold



90% recycled stainless steel

To Go Click 0.4 l



4.5 hours warm



9 hours cold



90% recycled stainless steel

To Go Sip 0.4 l



3 hours warm



6 hours cold



90% recycled stainless steel

Keep Cool 0.6 l



16 hours warm



32 hours cold



90% recycled stainless steel



NEW



LEFT: To Go Click and Keep Cool soft fern green.
RIGHT: To Go Click and Keep Cool soft white and soft black.

MADE FOR 100% RAW ADVENTURE



My Journey keychain, my Tabi bottle—designed to move with me. Thoughtful, durable essentials for life on the go. Made for everyday adventures and the moments in between.

Tabi vacuum insulated bottle 1 l.

10 warm

20 hours cold

90% recycled stainless steel



Tabi vacuum insulated bottle 0.55 l.

10 warm

20 hours cold

90% recycled stainless steel

Tabi vacuum insulated cup 0.4 l.

10 warm

20 hours cold

90% recycled stainless steel

DESIGNED WITH DEDICATION

”Together with our talented and carefully selected designers, we create results through close collaboration and a dynamic atmosphere that drives everything we do.”

—Mads Ring Damgaard, CEO Stelton



Erik Magnussen



Arne Jacobsen



Studio Terhedebrügge



Vibeke Klint



Michael Ring



Jehs+Laub



Defne Kozby



Francis Cayouette



Søren Refsgaard



Norman Foster



Tias Eckhoff



Niels Kjeldsen



Ulrik Nordentoft & Sebastian Holmbäck



Peter Holmblad



Böttcher & Kayser



Maria Berntsen



Daniel Debiasi & Federico Sandri



Klaus Rath



Kazushige Miyake



Johan Verde



CRAFTED WITH CONSIDERATION

Since 1960, Stelton has crafted kitchenware and home accessories made to withstand daily use and evolving trends. Longevity, usability, and timeless design remain at the heart of our philosophy.

Conscious material selection

We select materials with care and intention, favouring recycled, and verifiably sourced options where they bring true value to the product. We continuously follow developments in material innovation to ensure that our production choices remain safe, efficient, and aligned with the highest quality standards. Every choice is guided by transparency, traceability, and a long-term perspective.

Built on expertise

Enduring quality begins with the hands and minds behind each design. We collaborate closely with designers and manufacturing partners who share our expectations for precision, wellbeing, and consistency. This collaborative approach results in products that reflect both skill and dedication.

Thoughtful transport

Thoughtful planning reduces waste throughout the journey from production to home. We prioritise full-container shipping, efficient freight consolidation, and careful coordination that limits unnecessary air transport. By optimising logistics, we reduce excess transport and support smoother product flow, ensuring our designs travel with minimal footprint and maximum efficiency.

Long-term mindset

From the earliest stages of development, we consider the full lifespan of each product; how it is made, how it will be used, and how it can be maintained over time. Many of our designs include available spare parts, enabling customers to repair and extend the life of their product. This forward-looking approach also guides decisions about material safety, and durability.

Cylinda-line



Arne Jacobsen coffee pot
1.5 l
Design: Arne Jacobsen
art. no. 01-2



Arne Jacobsen French press
1 l
Design: Arne Jacobsen
art. no. 01-3



Arne Jacobsen tea pot
1.25 l
Design: Arne Jacobsen
art. no. 04-2



Arne Jacobsen creamer
0.15 l
Design: Arne Jacobsen
art. no. 06-2



Arne Jacobsen sugar bowl
Design: Arne Jacobsen
art. no. 06-3



Arne Jacobsen toast rack
Design: Arne Jacobsen
art. no. 013-1



Arne Jacobsen salt & pepper set
6.5 cm
Design: Arne Jacobsen
art. no. 010-1



Arne Jacobsen salt mill
Design: Arne Jacobsen
art. no. 017-3



Arne Jacobsen pepper mill
Design: Arne Jacobsen
art. no. 017-1



Arne Jacobsen salad servers
31 cm
Design: Arne Jacobsen
art. no. 023-1



EM nut & lobster cracker
Design: Erik Magnussen
art. no. 465



EM cake knife/spade
Design: Erik Magnussen
art. no. 460



EM lasagne spade
Design: Erik Magnussen
art. no. 463



Stelton reusable straw
4 pcs. - steel
Design: Stelton
art. no. 536



Arne Jacobsen jug with icelip
2 l
Design: Arne Jacobsen
art. no. 03-3



Arne Jacobsen serving tray
Design: Arne Jacobsen
art. no. 014-2



Arne Jacobsen champagne cooler
Design: Arne Jacobsen
art. no. 05-5



Arne Jacobsen cocktail shaker
0.75 l
Design: Arne Jacobsen
art. no. 016-1



Arne Jacobsen martini mixer
with spoon
1 l
Design: Arne Jacobsen
art. no. 020-1



Orlo serving tray
H 10 cm
Design: Defne Kozi
art. no. 630



Orlo serving tray
H 8 cm
Design: Defne Kozi
art. no. 631



Orlo serving tray
H 4 cm
Design: Defne Kozi
art. no. 632



Arne Jacobsen ice bucket
1 l
Design: Arne Jacobsen
art. no. 05-1



Arne Jacobsen ice bucket
2.5 l
Design: Arne Jacobsen
art. no. 05-2



Arne Jacobsen ice tongs
Design: Arne Jacobsen
art. no. 015-1



Arne Jacobsen coaster 6 pcs.
Design: Arne Jacobsen
art. no. 019-1



Original flower watering can
1.7 l. - steel
Design: Peter Holmblad
art. no. 100-15



Original flower watering can
1.7 l. - soft dark forest*
Design: Peter Holmblad
art. no. 100-16



Original flower watering can
1.7 l. - soft black*
Design: Peter Holmblad
art. no. 100-17



Original flower watering can
1.7 l. - soft sand*
Design: Peter Holmblad
art. no. 100-18



Arne Jacobsen revolving ashtray
small
Design: Arne Jacobsen
art. no. 09-1



Arne Jacobsen revolving ashtray
large
Design: Arne Jacobsen
art. no. 09-2

Classic

Classic



Brus carbonator steel
Design: Søren Refsgaard
art. no. 2100



Brus carbonator black metallic
Design: Søren Refsgaard
art. no. 2100-1



Brus carbonator brown metallic
Design: Søren Refsgaard
art. no. 2100-2



Brus carbonator brushed brass
Design: Søren Refsgaard
art. no. 2100-3



Brus carbonator soft sand
Design: Søren Refsgaard
art. no. 2100-4



Brus carbonator soft dark forest
Design: Søren Refsgaard
art. no. 2100-5



Brus carbonator soft white
Design: Søren Refsgaard
art. no. 2100-6

NEW



Brus wall mount carbonator steel
Design: Søren Refsgaard
art. no. 2102



Brus wall mount carbonator black metallic
Design: Søren Refsgaard
art. no. 2102-1



Brus carbonating bottle 1.15 l.
Design: Søren Refsgaard
art. no. 2101



Brus carbonating bottle 0.9 l. - steel
Design: Søren Refsgaard
art. no. 2103



Brus water filter jug 1.6 l.
Design: Søren Refsgaard
art. no. 2105

NEW



Brus Clear+ filter granules 3 pcs.
art. no. 2106

NEW



Brus Magnesium+ filter granules 3 pcs.
art. no. 2106-1

NEW



Pilastro long drink glass 4 pcs. - 0.3 l
Design: Francis Cayouette
art. no. x-509



Pilastro drinking glass 4 pcs. - 0.35 l
Design: Francis Cayouette
art. no. x-505



Pilastro drinking glass 6 pcs. - 0.24 l
Design: Francis Cayouette
art. no. x-502



Pilastro drinking glass 6 pcs. - 0.13 l
Design: Francis Cayouette
art. no. x-521



Pilastro wine glass 4 pcs. - 0.18 l
Design: Francis Cayouette
art. no. x-520

NEW



Pilastro tapas set
Design: Francis Cayouette
art. no. x-512



Pilastro serving bowl Ø 15 cm
Design: Francis Cayouette
art. no. x-505



Pilastro serving bowl Ø 23 cm
Design: Francis Cayouette
art. no. x-506



Pilastro serving bowl Ø 21 cm
Design: Francis Cayouette
art. no. x-513



Pilastro ovenproof dish L 19.7 cm
Design: Francis Cayouette
art. no. x-517



Pilastro ovenproof dish L 33.1 cm
Design: Francis Cayouette
art. no. x-518



Pilastro ovenproof dish L 40.8 cm
Design: Francis Cayouette
art. no. x-519



Pilastro ovenproof Pie dish Ø 24 cm
Design: Francis Cayouette
art. no. x-527

NEW



Pilastro ovenproof Pie dish Ø 28 cm
Design: Francis Cayouette
art. no. x-528

NEW



Pilastro carafe with 0.13 l glass
Design: Francis Cayouette
art. no. x-507



Pilastro cocktail shaker
Design: Francis Cayouette
art. no. x-510



Pilastro wine cooler
Design: Francis Cayouette
art. no. x-504



Pilastro storage jar 0.6 l
Design: Francis Cayouette
art. no. x-525

NEW



Pilastro storage jar 1.3 l
Design: Francis Cayouette
art. no. x-526

NEW

Classic



EM77 vacuum jug steel
Design: Erik Magnussen
1 l. - art. no. 900
0.5 l. - art. no. 915



EM77 electric kettle 1.5l steel
Design: Erik Magnussen
art. no. 891



EM77 creamer steel
Design: Erik Magnussen
art. no. 1000



Dripper for vacuum jug
Design: Stelton
art. no. 1020



Tea strainer for EM77
Design: Stelton
art. no. 999



EM77 vacuum jug black
Design: Erik Magnussen
1 l. - art. no. 930
0.5 l. - art. no. 935



EM77 electric kettle black
Design: Erik Magnussen
1.5 l. - art. no. 890
0.5 l. - art. no. 892



EM77 French press 1 l black
Design: Erik Magnussen
art. no. 812



EM77 vacuum jug white
Design: Erik Magnussen
1 l. - art. no. 960
0.5 l. - art. no. 965



EM77 electric kettle white
Design: Erik Magnussen
1.5 l. - art. no. 890-1
0.5 l. - art. no. 892-1



EM77 French press 1 l white
Design: Erik Magnussen
art. no. 811



EM77 vacuum jug 1 l light grey
Design: Erik Magnussen
art. no. 918



EM77 electric kettle 1.5 l light grey
Design: Erik Magnussen
art. no. 890-2



EM77 vacuum jug 1 l sand
Design: Erik Magnussen
art. no. 1800



EM77 electric kettle 1.5 l sand
Design: Erik Magnussen
art. no. 890-8*



EM77 vacuum jug 1 l heather
Design: Erik Magnussen
art. no. 995-9



EM77 electric kettle 1.5 l heather
Design: Erik Magnussen
art. no. 890-7



EM77 vacuum jug 1 l art. no. 995-12* (soft fern green) / 995-13* (soft cloud) / 995-3 (soft black) / 991 (granite grey) / 920 (red) / 974* (dark forest) / 919 (dusty green) / 985 (cloud) / 997 (lavender) / 995-11* (wheat)
Design: Erik Magnussen

Classic



EM77 jug with lid 1.5 l. - smoke
Design: Erik Magnussen
art. no. 1310-8



EM77 jug with lid 1.5 l. - dusty green
Design: Erik Magnussen
art. no. 1310-7



EM77 jug with lid 1.5 l. - blue
Design: Erik Magnussen
art. no. 1310



EM77 water filter jug 2 l.
Design: Erik Magnussen
smoke - art. no. 1310-10
blue - art. no. 1310-13



Magnesium+ Water filter 3 pcs.
Design: Stelton
art. no. 1334



EM serving tray Ø 40 - black
Design: Erik Magnussen
art. no. 1309



EM serving tray Ø 40 - dusty green
Design: Erik Magnussen
art. no. 1309-1



EM serving tray Ø 40 - cloud
Design: Erik Magnussen
art. no. 1309-3



Bread bag large - black
Design: Klaus Rath
art. no. 1320



Bread bag large - black/sand
Design: Klaus Rath
art. no. 1322



Bread bag large - sand/white
Design: Klaus Rath
art. no. 1323



Bread bag large - heather
Design: Klaus Rath
art. no. 1320-1*



Stelton mug 2 pcs. - light grey
Design: Søren Refsgaard
art. no. 1142-1



Stelton mug 2 pcs. - dusty green
Design: Søren Refsgaard
art. no. 1142-2



Stelton mug 2 pcs. - lavender
Design: Søren Refsgaard
art. no. 1142

Classic



EM ship's lamp
15 x34 cm
Design: Erik Magnussen
art. no. 1004



EM ship's lamp
27x43 cm
Design: Erik Magnussen
art. no. 1001



EM LED ship's lamp
27x43 cm
Design: Erik Magnussen
art. no. 1001-1



LED-light for EM ship's lamp
Design: Erik Magnussen
art. no. 1001-11



Hurricane - black
Design: Maria Berntsen
H 24.5 cm - art. no. 495
H 28.5 cm - art. no. 496



Lucie hurricane
Design: Francis Cayouette
amber - art. no. 497-1
azure - art. no. 497-2



Stelton Time wall clock
Ø 30 cm - black
Design: Jehs+Laub
art. no. 851

Nordic



Theo teapot - sand
1.25 l
Design: Francis Cayouette
art. no. x-630-1



Theo teapot warmer - sand
Design: Francis Cayouette
art. no. x-631-1



Theo coffee maker - sand
0.6 l
Design: Francis Cayouette
art. no. x-634-1



Theo cup with coaster - sand
Design: Francis Cayouette
0.2 l - art. no. x-632-1
0.25 l - art. no. x-641-1



Theo teapot - black
1.25 l
Design: Francis Cayouette
art. no. x-630



Theo teapot warmer - black
Design: Francis Cayouette
art. no. x-631



Theo coffee maker - black
0.6 l
Design: Francis Cayouette
art. no. x-634



Theo cup with coaster - black
Design: Francis Cayouette
0.2 l - art. no. x-632
0.25 l - art. no. x-641



Theo serving tray bamboo
Design: Francis Cayouette
art. no. x-643



Theo French press - black
0.8 l
Design: Francis Cayouette
art. no. x-636



Theo milk jug and sugar bowl
black
Design: Francis Cayouette
milk jug 0.4 l. - art. no. x-638
sugar bowl - art. no. x-637



Theo mug 2 pcs. - black
Design: Francis Cayouette
art. no. x-639



Theo lunch plate 2 pcs. - black
Design: Francis Cayouette
art. no. x-640



Collar espresso maker 0.25 l
Design: Debiasi & Sandri
art. no. 420



Collar coffee grinder
Design: Debiasi & Sandri
423-1 (steel)



Collar vacuum bottle stopper
Design: Debiasi & Sandri
art. no. 419



Nohr gooseneck kettle
black metallic
Design: Søren Refsgaard
art. nr. 610



Nohr glass server
black metallic
Design: Søren Refsgaard
art. nr. 611



Nohr slow brew dripper with filter
black metallic
Design: Søren Refsgaard
art. nr. 612



Nohr filter for cold brew
black metallic
Design: Søren Refsgaard
art. nr. 613

Nordic



Ora vase
neo mint / midnight blue
H 21.6 cm
Design: Debiasi & Sandri
art. no. 109



Ora vase
dusty blue / midnight blue
H 17.9 cm
Design: Debiasi & Sandri
art. no. 108



Ora bowl
neo mint / midnight blue
Ø 30 cm
Design: Debiasi & Sandri
art. no. 102



Ora bowl
dusty blue / midnight blue
Ø 22 cm
Design: Debiasi & Sandri
art. no. 101



Ora bowl
dark forest / midnight blue
Ø 15 cm
Design: Debiasi & Sandri
art. no. 100



Ora vase
dark powder / powder
H 21.6 cm
Design: Debiasi & Sandri
art. no. 109-1



Ora vase
dusty rose / powder
H 17.9 cm
Design: Debiasi & Sandri
art. no. 108-1



Ora bowl
dark powder / powder
Ø 30 cm
Design: Debiasi & Sandri
art. no. 102-1



Ora bowl
dusty rose / powder
Ø 22 cm
Design: Debiasi & Sandri
art. no. 101-1



Ora bowl
warm maroon / powder
Ø 15 cm
Design: Debiasi & Sandri
art. no. 100-1



Ora three-armed candleholder
black
Design: Debiasi & Sandri
art. no. 110



Ora
candleholder / tealightholder
steel
Design: Debiasi & Sandri
H 6.5 cm - art. no. 103
H 8 cm - art. no. 104



Ora
candleholder / tealightholder
beech wood
Design: Debiasi & Sandri
H 6.5 cm - art. no. 103-1
H 8 cm - art. no. 104-1



Ora tealightholder 2 pcs.
smoke
Design: Debiasi & Sandri
art. no. 107



Hoop hurricane
black
Design: UNIT 10
art. no. 618



Bloom watering can
2 l. - pine
Design: Böttcher & Kayser
art. nr. 345

Nordic



Vinkel portable LED lamp
black
Design: Studio Terhedebrügge
art. nr. 625



Vinkel LED solar lamp with spike
black
Design: Studio Terhedebrügge
art. nr. 626



Pier portable LED lamp
black
Design: Søren Refsgaard
25 cm - art. nr. 614
33.5 cm - art. nr. 616



Pier portable LED lamp
sand
Design: Søren Refsgaard
25 cm - art. nr. 614-1
33.5 cm - art. nr. 616-1



Take away serving tray
Design: Klaus Rath
art. no. x-8



Okiru alarm clock
Design: Kazushige Miyake
black - art. no. 401



Fjord shower wiper
black
Design: Debiasi & Sandri
art. nr. 116



Fjord mirror
black
Design: Debiasi & Sandri
art. nr. 117



Fjord
black
Design: Debiasi & Sandri
toilet brush - art. nr. 118
toilet brush head - art. nr. 119



Fjord
black
Design: Debiasi & Sandri
dispenser 0.3 l. - art. nr. 111
toothbrush holder - art. nr. 113
tray - art. nr. 115



Fjord soap dish Ø 11 cm
black
Design: Debiasi & Sandri
art. nr. 112

Danish Modern 2.0



Emma electric kettle
1.2l. - steel
Design: HolmbäckNordentoft
art. no. x-210-10



Emma vacuum jug coffee
1l. - steel
Design: HolmbäckNordentoft
art. no. x-200-10



Emma vacuum jug tea
1l. - steel
Design: HolmbäckNordentoft
art. no. x-201-10



Emma French press
1l. - steel
Design: HolmbäckNordentoft
art. no. x-239-10



Emma electric kettle
1.2l. - soft sand
Design: HolmbäckNordentoft
art. no. x-210-9



Emma vacuum jug coffee
1l. - soft sand
Design: HolmbäckNordentoft
art. no. x-200-9



Emma vacuum jug tea
1l. - soft sand
Design: HolmbäckNordentoft
art. no. x-201-9



Emma French press
1l. - soft sand
Design: HolmbäckNordentoft
art. no. x-239



Emma electric kettle
1.2l. - grey
Design: HolmbäckNordentoft
art. no. x-210-1



Emma vacuum jug coffee
1l. - grey
Design: HolmbäckNordentoft
art. no. x-200-1



Emma vacuum jug tea
1l. - grey
Design: HolmbäckNordentoft
art. no. x-201-1



Emma electric kettle
1.2l. - blue
Design: HolmbäckNordentoft
art. no. x-210



Emma vacuum jug tea
1l. - blue
Design: HolmbäckNordentoft
art. no. x-201



Emma electric kettle
1.2l. - soft
Design: HolmbäckNordentoft
art. no. x-210-22



Emma electric kettle
1.2l. - black
Design: HolmbäckNordentoft
art. no. x-210-2



Emma vacuum jug coffee
1l. - black
Design: HolmbäckNordentoft
art. no. x-200-2



Emma vacuum jug tea
1l. - black
Design: HolmbäckNordentoft
art. no. x-201-2



Emma electric kettle
1.2l. - soft dark blue
Design: HolmbäckNordentoft
art. no. x-210-7

Danish Modern 2.0



Emma cup 2 pcs.
0.15l. - grey
Design: HolmbäckNordentoft
art. no. x-233



Emma milk jug
0.3l. - grey
Design: HolmbäckNordentoft
art. no. x-235



Emma bowl 2 pcs.
Ø 13.5 cm - grey
Design: HolmbäckNordentoft
art. no. x-236



Emma plate 2 pcs.
Ø 19 cm - grey
Design: HolmbäckNordentoft
art. no. x-237



Emma plate 2 pcs.
Ø 24 cm - grey
Design: HolmbäckNordentoft
art. no. x-238



Emma cup 2 pcs.
0.15l. - rose
Design: HolmbäckNordentoft
art. no. x-233-1



Emma cup 2 pcs.
0.22l. - rose
Design: HolmbäckNordentoft
art. no. x-234-1



Emma milk jug
0.3l. - rose
Design: HolmbäckNordentoft
art. no. x-235-2



Emma bowl 2 pcs.
Ø 13.5 cm - rose
Design: HolmbäckNordentoft
art. no. x-236-1



Emma plate 2 pcs.
Ø 19 cm - rose
Design: HolmbäckNordentoft
art. no. x-237-1



Emma plate 2 pcs.
Ø 24 cm - rose
Design: HolmbäckNordentoft
art. no. x-238-1



Emma kitchen roll holder
grey
Design: HolmbäckNordentoft
art. no. x-227



Emma cup 2 pcs.
blue
Design: HolmbäckNordentoft
art. no. x-208



Emma saucer 2 pcs.
blue
Design: HolmbäckNordentoft
art. no. x-212



Emma plate 2 pcs.
Ø 18 cm - blue
Design: HolmbäckNordentoft
art. no. x-209



Emma plate 2 pcs.
Ø 22 cm - grey
Design: HolmbäckNordentoft
art. no. x-219-1

Danish Modern 2.0



Amphora vacuum jug coffee
1 L - soft peach
Design: Sebastian Holmbäck
art. no. 221-2



Amphora vacuum jug coffee
1 L - soft black
Design: Sebastian Holmbäck
art. no. 221-1



Amphora vacuum jug coffee
1 L - soft white
Design: Sebastian Holmbäck
art. no. 221



Amphora vacuum jug
1.2 L - steel
Design: Sebastian Holmbäck
art. no. 228



Amphora vacuum jug tea
1 L - soft peach
Design: Sebastian Holmbäck
art. no. 222-2



Amphora vacuum jug tea
1 L - soft black
Design: Sebastian Holmbäck
art. no. 222-1



Amphora vacuum jug tea
1 L - soft white
Design: Sebastian Holmbäck
art. no. 222



Solis oil lamp
Design: Søren Refsgaard
soft black - art. no. 415
brass - art. no. 415-1



Ro Qi wireless charger
Design: Niels Kjeldsen
art. no. 399

Soft Home



Vibeke Klint bedding
white
Design: Vibeke Klint
art. no.
2200-NO (140x200 cm/50x70 cm)
2200 (140x200 cm/60x63 cm)



Vibeke Klint bedding
blue
Design: Vibeke Klint
art. no.
2200-1-NO (140x200 cm/50x70 cm)
2200-1 (140x200 cm/60x63 cm)



Vibeke Klint bedding
green
Design: Vibeke Klint
art. no.
2200-2-NO (140x200 cm/50x70 cm)
2200-2 (140x200 cm/60x63 cm)



Vibeke Klint bedding
red
Design: Vibeke Klint
art. no.
2200-3-NO (140x200 cm/50x70 cm)
2200-3 (140x200 cm/60x63 cm)

Norstaal



Maya cutlery
Design: Tias Eckhoff
Set 24 pcs. - art. no. C-2-24
Dinner fork - art. no. 13202
Dinner spoon - art. no. 13102
Dinner knife - art. no. 30502
Tea spoon - art. no. 14502
Coffee spoon - art. no. 11302
Dessert spoon - art. no. 11102
Dessert fork - 11202



Maya 2000 cutlery
Design: Tias Eckhoff
Set 24 pcs. - art. no. C-18-24
Dinner fork - art. no. 13222
Dinner spoon - art. no. 13122
Dinner knife - art. no. 30522



Maya cake spade
Design: Tias Eckhoff
art. no. 18903



Chaco cutlery
Design: Tias Eckhoff
Set 24 pcs. - art. no. C-4-24
Dinner fork - art. no. 13205
Dinner spoon - art. no. 13105
Dinner knife - art. no. 30505
Coffee-/tea spoon - art. no. 14505
Dessertspoon - art. no. 11105
Dessert fork - art. no. 11205



Chaco sauce ladle
Design: Tias Eckhoff
art. no. 14305



Foster dish
Ø 46 cm - steel - golden
Design: Norman Foster
art. no. 710



Foster French press vacuum jug
1 l. - steel
Design: Norman Foster
art. no. 770



Foster press tea maker vacuum jug
1 l. - steel
Design: Norman Foster
art. no. 780



Aztec cutlery
Design: Don Wallace
Dinner spoon - art. no. 13108
Coffee-/tea spoon - art. no. 11308



Capelano cutlery
Design: Johan Verde
Dinner knife - art. no. 30560
Dinner fork - art. no. 13260
Dinner spoon - art. no. 13160
Coffee-/tea spoon - art. no. 14560
Dessert spoon - art. no. 11160
Dessert fork - art. no. 11260



EM cutlery
Design: Erik Magnussen
Dinner fork - art. no. 541
Dinner knife - art. no. 542
Dinner spoon - art. no. 543
Dessert fork - art. no. 544
Coffee spoon - art. no. 547



Magnum cutlery
Design: Don Wallace
Dinner spoon - art. no. 13109
Coffee-/tea spoon - art. no. 14509
Dessert fork - art. no. 11209



Una cutlery
Design: Tias Eckhoff
Dinner spoon - art. no. 13107



Foster sugar bowl
porcelain
Design: Norman Foster
art. no. 791



Foster tumbler
0.2 l. - glass
Design: Norman Foster
art. no. 731



Foster salt mill
light grey
Design: Norman Foster
art. no. 725-1



Pure Black knife set
paring knife, santoku knife,
chef's knife, and bread knife
Design: HolmbäckNordentoft
art. no. 380



Pure Black
boning knife
Design: HolmbäckNordentoft
art. no. x-120-6



Trigono
boning knife
Design: Simon Kalmer
art. no. 353

l:cons



To Go Click – soft black vacuum insulated cup
Design: Ring
0.2 l. – art. no. 675-1
0.4 l. – art. no. 685-1

To Go Click – soft chalk vacuum insulated cup
Design: Ring
0.2 l. – art. no. 675-3
0.4 l. – art. no. 685-3

To Go Click – soft light grey vacuum insulated cup
Design: Ring
0.2 l. – art. no. 675-13
0.4 l. – art. no. 685-13

To Go Click – soft fern green vacuum insulated cup
Design: Ring
0.2 l. – art. no. 675-26*
0.4 l. – art. no. 685-26*

To Go Click – soft mellow yellow vacuum insulated cup
Design: Ring
0.2 l. – art. no. 675-46*
0.4 l. – art. no. 685-46*

To Go Click – soft rose vacuum insulated cup
Design: Ring
0.2 l. – art. no. 675-36
0.4 l. – art. no. 685-36



To Go Click – black vacuum insulated cup
Design: Ring
0.2 l. – art. no. 675-1
0.4 l. – art. no. 685-1

To Go Click – chalk vacuum insulated cup
Design: Ring
0.2 l. – art. no. 675-3
0.4 l. – art. no. 685-3

To Go Click – soft cloud vacuum insulated cup
Design: Ring
0.2 l. – art. no. 675-27
0.4 l. – art. no. 685-27

To Go Click – soft dark forest vacuum insulated cup
Design: Ring
0.2 l. – art. no. 675-26*
0.4 l. – art. no. 685-26*

To Go Click – soft laevis vacuum insulated cup
Design: Ring
0.2 l. – art. no. 675-49*
0.4 l. – art. no. 685-49*

To Go Click – soft heather vacuum insulated cup
Design: Ring
0.2 l. – art. no. 675-50*
0.4 l. – art. no. 685-50*



To Go Click – black metallic vacuum insulated cup
Design: Ring
0.2 l. – art. no. 675-16
0.4 l. – art. no. 685-16

To Go Click – steel vacuum insulated cup
Design: Ring
0.2 l. – art. no. 675
0.4 l. – art. no. 685

To Go Click – blue metallic vacuum insulated cup
Design: Ring
0.2 l. – art. no. 675-18
0.4 l. – art. no. 685-18

To Go Sip – soft black vacuum insulated cup with straw
Design: Ring
0.4 l. – art. no. 686-51

To Go Sip – soft laevis vacuum insulated cup with straw
Design: Ring
0.4 l. – art. no. 686-49*

To Go Sip – soft heather vacuum insulated cup with straw
Design: Ring
0.4 l. – art. no. 686-50



Keep Cool vacuum insulated bottle 0.6 l.
Design: Debiasi & Sandri
art. nr. 355-29 (soft chalk*) / 355-13 (soft light grey) / 355-3 (soft black) / 355-15 (steel) / 355-28 (soft fern green)
355-26 (soft dark forest) / 335-14 (soft rose) / 355-25* (soft heather) / 355-21* (soft mellow yellow) / 355-24* (soft laevis)



Keep Warm vacuum insulated bottle 0.75 l. – soft black
Design: Debiasi & Sandri
art. no. 366

l:cons



Tabi vacuum insulated bottle 1 l. black
Design: Kazushige Miyake
art. no. 373

Tabi vacuum insulated bottle 1 l. steel
Design: Kazushige Miyake
art. no. 373-3



Tabi vacuum insulated bottle 0.55 l. black
Design: Kazushige Miyake
art. no. 372

Tabi vacuum insulated bottle 0.55 l. steel
Design: Kazushige Miyake
art. no. 372-3

Tabi vacuum insulated bottle 0.55 l. dusty green
Design: Kazushige Miyake
art. no. 372-4



Tabi vacuum insulated cup 0.4 l. black
Design: Kazushige Miyake
art. no. 370

Tabi vacuum insulated cup 0.4 l. soft ice blue
Design: Kazushige Miyake
art. no. 370-1

Tabi vacuum insulated cup 0.4 l. dusty rose
Design: Kazushige Miyake
art. no. 370-2



Flap tablet-holder
Design: Jørgen Fenger
art. no. x-1

Companion cardholder
Design: Søren Refsgaard
art. no. 233

Journey ice scraper
Design: Søren Refsgaard
art. no. 234

Journey keychain
Design: Søren Refsgaard
art. no. 235

Stelton x Moomin



stelton
×
MOOMIN

Our Moomin collection of reusable vacuum insulated cups and drinking bottles is ideal for children and adults who love adventure and freedom, just like the Moomins themselves. With the vacuum insulated cup in your bag, it's easy to enjoy hot and cold beverages when you're on the go, exploring the city or the woods, at school or at work. The vacuum-insulated cups can be filled with hot drinks when it's cold outside, or how about taking along a few scoops of the kids' favourite ice cream on a picnic in the summertime? The cups can keep their contents cold just as well as they keep the heat.



Stelton x Moomin - I Love You
vacuum insulated cup 0.2 l. - art. no. 1370-18*



Stelton x Moomin - Moominmamma
vacuum insulated cup 0.2 l. - art. no. 1370-19*



Stelton x Moomin - Courage
vacuum insulated cup 0.2 l. - art. no. 1370-20*



Stelton x Moomin - Moominmamma's Tea party
vacuum insulated cup 0.2 l. - art. no. 1370-14*



Stelton x Moomin - Moomin Home
vacuum insulated cup 0.2 l. - art. no. 1370-17*



Stelton x Moomin - Moomin Camping
drinking bottle 0.75 l. - art. no. 1372-8*
vacuum insulated cup 0.2 l. - art. no. 1370-8*
vacuum insulated cup 0.4 l. - art. no. 1371-8*



Stelton x Moomin - Moomin Present
drinking bottle 0.75 l. - art. no. 1372-9*
vacuum insulated cup 0.2 l. - art. no. 1370-9*
vacuum insulated cup 0.4 l. - art. no. 1371-9*



Stelton x Moomin - Moomin Frost
drinking bottle 0.75 l. - art. no. 1372-6*



Stelton x Moomin - Sky
Carrie
vacuum insulated mug 0.4 l. art. no. 1375-7*
vacuum insulated drinking bottle 0.5 l. art. no. 1374-7*

stelton

www.stelton.com



@steltontdesign



@steltontdesign



@steltontdesign